

THIS DRAWING IS UNPUBLISHED. RELEASED FOR PUBLICATION
 © COPYRIGHT - BY TYCO ELECTRONICS CORPORATION. ALL RIGHTS RESERVED.

LOC	DIST	REVISIONS					
AJ	16	P	LTR	DESCRIPTION	DATE	DWN	APVD
			0	REL PER EC 0S14-0101-05	19APR2005	GA	JL

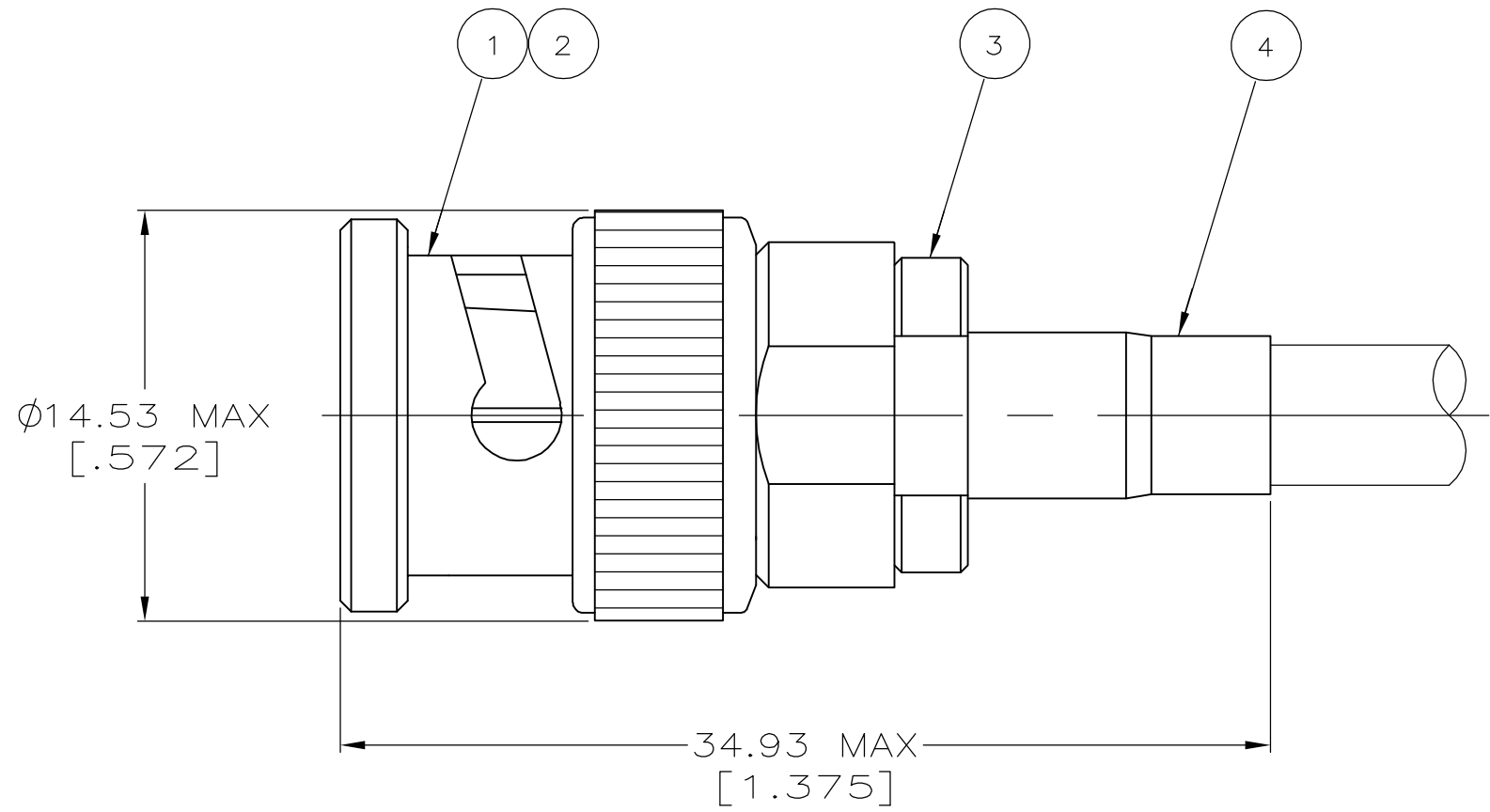

- 1. USE INSTRUCTION SHEET 408-1799-1
- ② USE CRIMP TOOL 69140-1 WITH CABLE RG-58/U, 58A/U, 58B/U, 58C/U
- ③ USE CRIMP TOOL 69140-2 WITH CABLE RG-55/U, 55A/U, 55B/U AND 223/U

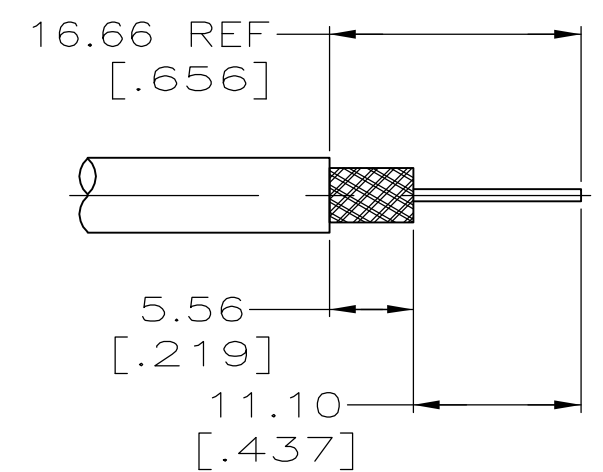

RECOMMENDED STRIP LENGTH
SCALE 2:1

③	9-329099-2	9-50780-0	2-329106-1	9-329804-0	2-5329444-2
②	9-328663-0	9-50780-0	2-329106-1	9-329804-0	2-5329444-1
④	FERRULE QTY=1	③ CRIMP END ASSEMBLY QTY=1	② GASKET QTY=1	① PLUG ASSEMBLY QTY=1	PART NUMBER

THIS DRAWING IS A CONTROLLED DOCUMENT.		DWN G. ATTADIA - DOCK5 19APR2005	Tyco Electronics Corporation Harrisburg, Pa 17105-3608	
DIMENSIONS: mm [INCHES]		CHK J. HAVENER 19APR2005	NAME	
		APVD J. LIPPERT 19APR2005	PRODUCT SPEC	
TOLERANCES UNLESS OTHERWISE SPECIFIED: 0 PLC ± - 1 PLC ± - 2 PLC ± 0.41 [.016] 3 PLC ± - 4 PLC ± - ANGLES ± -		APPLICATION SPEC		
MATERIAL		WEIGHT	SIZE	RESTRICTED TO
-		-	A3 00779	-
FINISH		DRAWING NO		REV
-		G-5329444		0
CUSTOMER DRAWING			SCALE 4:1	SHEET 1 OF 1